

PRO-LINE **PRO-MT4X4**

**1:10 4WD MONSTER TRUCK
PRE-BUILT ROLLER**



USER MANUAL

PRO-LINE PRO-MT4x4

1:10 4WD MONSTER TRUCK
PRE-BUILT ROLLER

Thank you for purchasing Pro-Line's PRO-MT 4x4! For Over 35 years, Pro-Line has designed and manufactured the best RC products in the world. This 1:10 scale 4x4 monster truck has been

developed from the ground up for extreme performance, durability, and most importantly, fun! Thank you for choosing the PRO-MT 4x4 and joining Team Pro-Line in making history!

The PRO-MT 4x4 comes as a pre-built roller. This manual contains instructions for completing and operating your vehicle. Please take time to familiarize yourself with the procedures for running and maintaining

your RC vehicle before driving. Pro-Line is continually improving our products; consequently, actual parts included in the PRO-MT 4x4 may appear slightly different than the images in this manual.

EQUIPMENT NEEDED



RADIO



RECEIVER



SERVO
(HORNS INCLUDED)

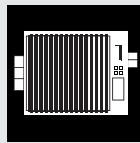

ESC

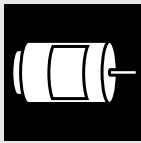

MOTOR
550 SIZE OR 1:8 SIZE

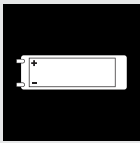

LIPO BATTERY
2S, 3S, OR 4S

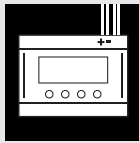

CHARGER

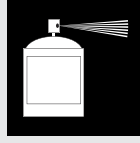

RC BODY PAINT
POLYCARBONATE SAFE

RECOMMENDED TOOLS



HEX DRIVERS
1.5MM, 2MM, 2.5MM



NUT DRIVER
5.5MM



SERVO TAPE



THREAD LOCK

INCLUDED TOOLS

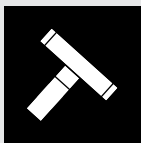

WHEEL WRENCH
17MM

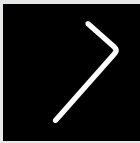

HEX KEY
3MM

PRECAUTIONS

To prevent serious personal injury and/or property damage, operate all remotely controlled models in a responsible manner as described herein.

Choose the right place to operate your RC model:

- Do not run RC vehicles on public streets or highways
- Do not run RC vehicles near people or animals
- Do not run RC vehicles where noise can disturb others

Inspect your vehicle before operation:

- Make sure that all screws and nuts are properly tightened
- Always use fresh batteries in your radio
- Always test the throttle and steering before setting the vehicle on the ground

After operation of your RC vehicle:

- To prevent a runaway, turn off the vehicle first, then the radio
- Replace any battery that has puffed or been dented or has frayed wiring
- Keep your vehicle clean and free of excess dirt and debris
- Immediately after use, do not touch any equipment on the vehicle such as the motor or ESC, as they could generate high temperatures and cause burns
- Store your vehicle and battery in a place where a fire cannot spread

WARNING!

This is NOT a toy and is NOT suitable for children under 14 years of age. This RC vehicle contains many small parts which are potential choking hazards. Keep all components out of reach of small children.

HEALTH WARNING!

This product contains chemicals known to the State of California to cause cancer, birth defects, or other reproductive harm. This RC vehicle is a high performance radio controlled model and can cause harm or personal injury. All liquids contained in this RC vehicle are not to be swallowed. Never touch rotating parts as this can cause injury.



SCAN FOR HELP

HELP AND INFORMATION

Installation manuals and videos can be found on our website at prolineracing.com/pro-mt4x4. If you need any technical assistance or have questions please call our tech support line at: 1-800-899-RACE(7223) or (951) 849-9781.



SCAN TO REGISTER

REGISTRATION

Register your PRO-MT 4x4 online at prolineracing.com/pro-mt4x4/register or call 1-800-899-RACE(7223) or (951) 849-9781.

GETTING STARTED: INSTALL ELECTRONICS

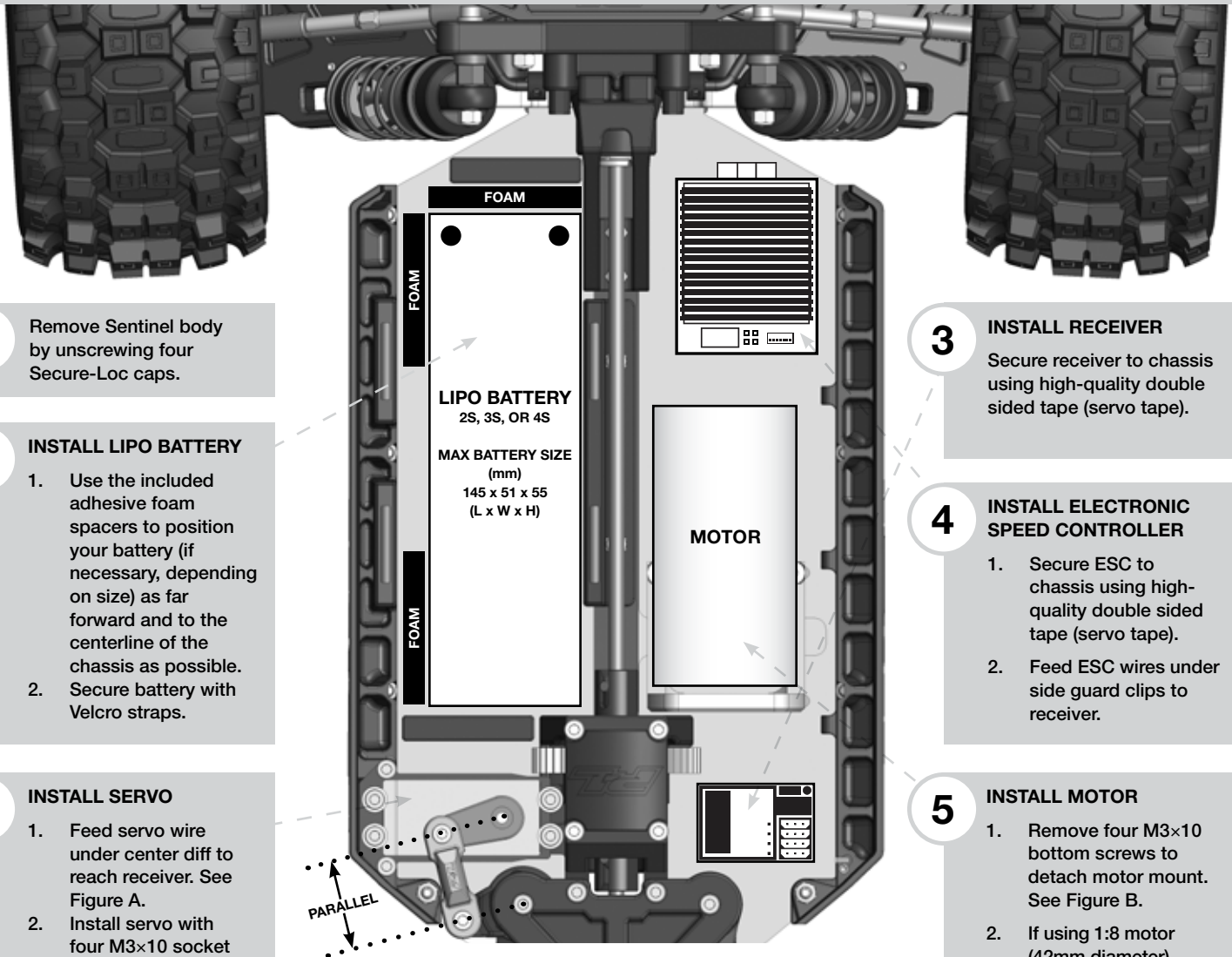

1 Remove Sentinel body by unscrewing four Secure-Loc caps.

2 **INSTALL LIPO BATTERY**

1. Use the included adhesive foam spacers to position your battery (if necessary, depending on size) as far forward and to the centerline of the chassis as possible.
2. Secure battery with Velcro straps.

3 **INSTALL RECEIVER**

Secure receiver to chassis using high-quality double sided tape (servo tape).

4 **INSTALL ELECTRONIC SPEED CONTROLLER**

1. Secure ESC to chassis using high-quality double sided tape (servo tape).
2. Feed ESC wires under side guard clips to receiver.

6 **INSTALL SERVO**

1. Feed servo wire under center diff to reach receiver. See Figure A.
2. Install servo with four M3×10 socket head screws and M3 washers.
3. Select the servo horn that matches the spline count on your servo.
23: Airtronics, JR, KO
24: Hitec
25: Futaba, Savox, ProTek
4. With radio and vehicle powered on and servo at neutral, install servo horn parallel to the connecting arm.
5. Secure servo horn with screw included with servo.

5 **INSTALL MOTOR**

1. Remove four M3×10 bottom screws to detach motor mount. See Figure B.
2. If using 1:8 motor (42mm diameter), remove motor support. See Figure C.
3. Select the correct gear mesh inserts for your pinion size. See detailed instructions for setting gear mesh on page 4.
4. Attach motor to motor mount using included screws: (2) M3×10 for 550 size or (2) M4×10 for 1:8 size.
5. Install motor mount assembly onto main chassis with four M3×10 screws, with gear mesh inserts.
6. Install pinion gear (#4005-10A) with M4×4mm set screw. See Figure D.

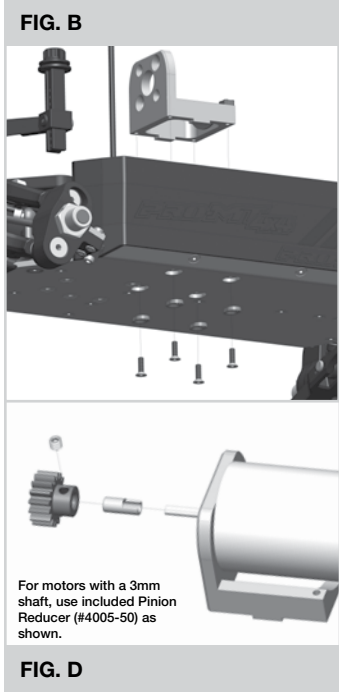
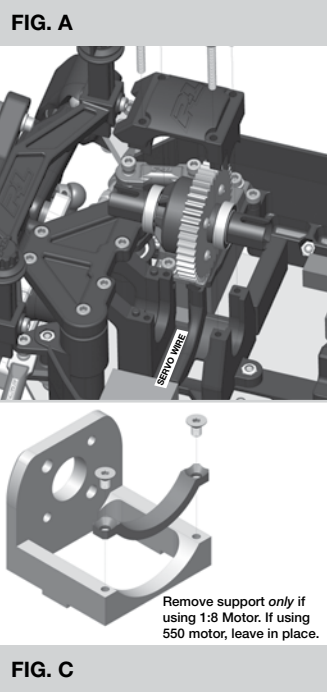

See a fully-wired, ready-to-bash PRO-MT 4x4 at prolineracing.com/pro-mt4x4

GETTING STARTED: SET GEAR MESH

PRO-MT 4x4 includes eccentric gear mesh inserts to properly set gear mesh depending on the pinion size you select. See the chart below to set the correct orientation when attaching your motor mount to the chassis. It is recommended to use thread lock to

secure the motor mount.







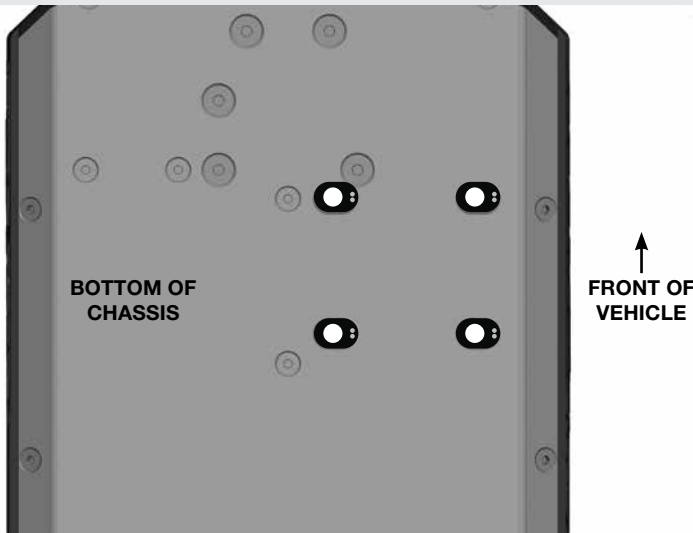

IMPORTANT!

Only use MOD1 pinion gears

IMPORTANT!

All four inserts must have the same orientation.



 = 14T	 = 21T
 = 15T	 = 20T
 = 16T STOCK SETTING FOR INCLUDED PINION	 = 19T
 = 17T	 = 18T

GETTING STARTED: FASTEN TIRES



Install Pre-mounted Badlands MX28 tires onto the 17mm hex drives and tighten wheel nuts (#4005-39) with the included wheel nut wrench (#4005-49B).

GETTING STARTED: PAINT BODY

1

1. Wash body with mild detergent, then rinse and dry thoroughly.
2. Apply window masks to inside of body.



2

1. For painting tips, visit www.prolineracing.com/how-to-tips-body-painting-novice
2. Use only polycarbonate-safe paint
3. Allow paint to dry completely
4. Remove window masks and outer film
5. Apply decals
6. Mount body to chassis using Secure-Loc Caps

CONGRATULATIONS!

You're now ready to bash one of the most extreme; durable, high-performance RC monster trucks ever developed!



PROMAX4

EXPLODED VIEW: FRONT

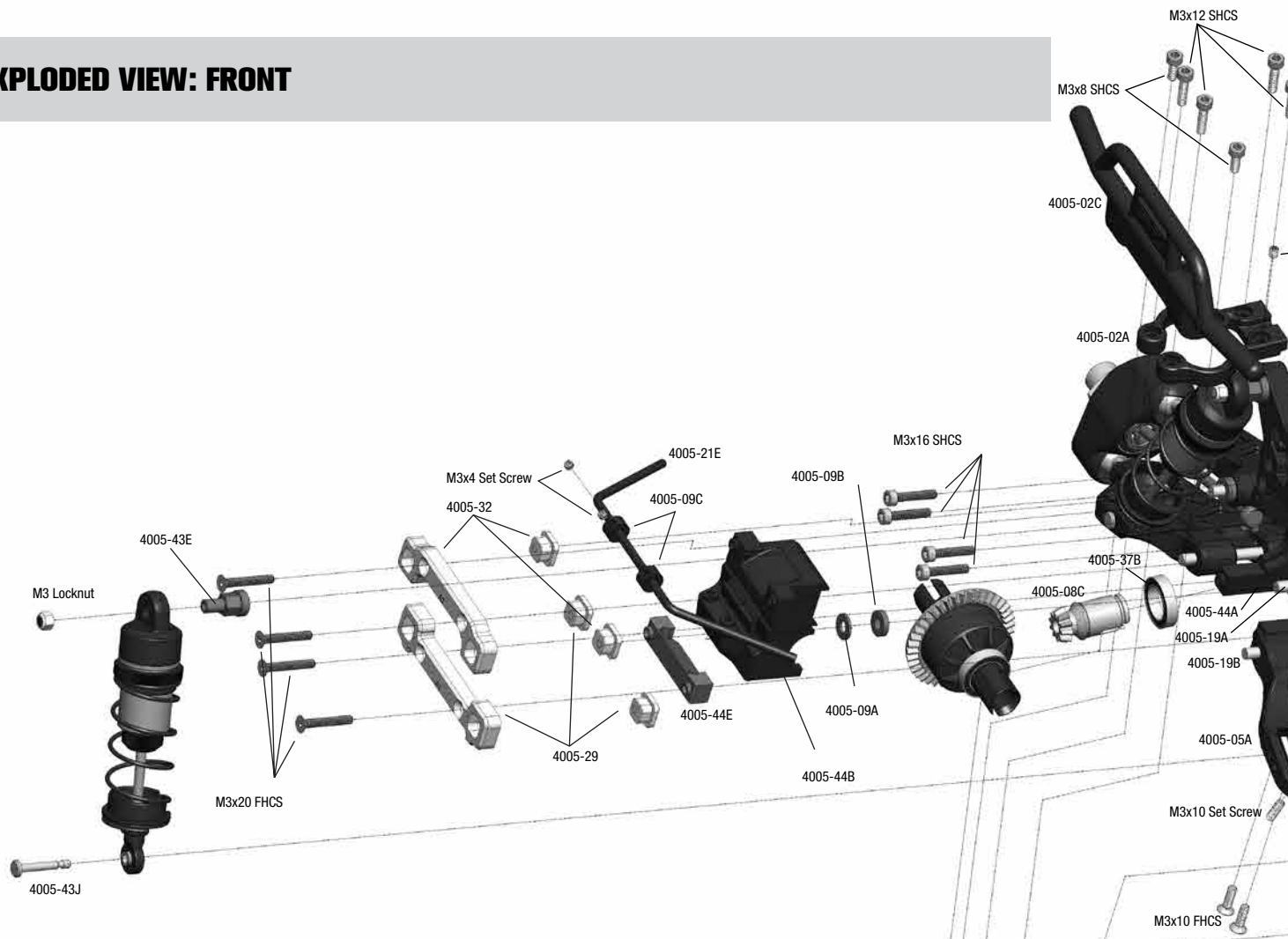

EXPLODED VIEW: DIFF

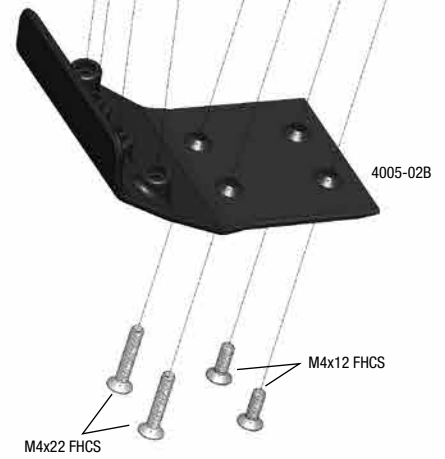
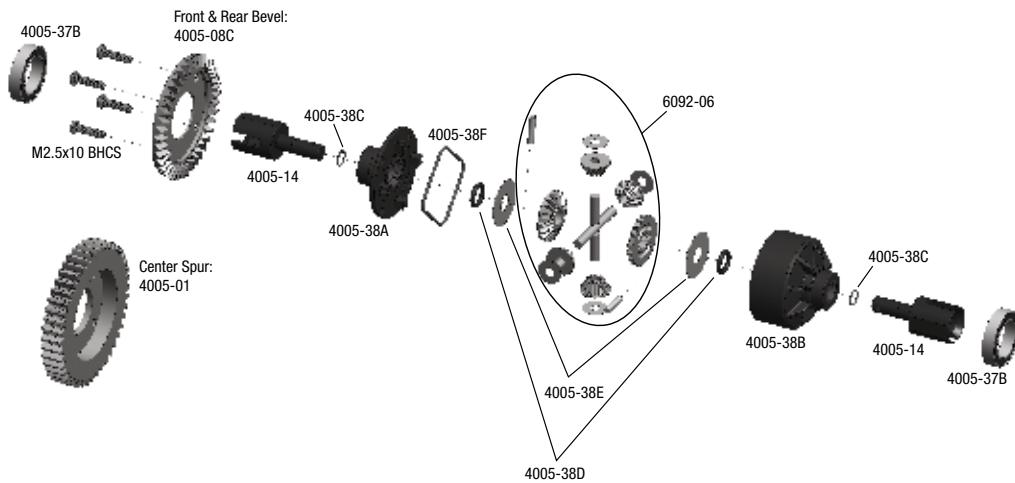

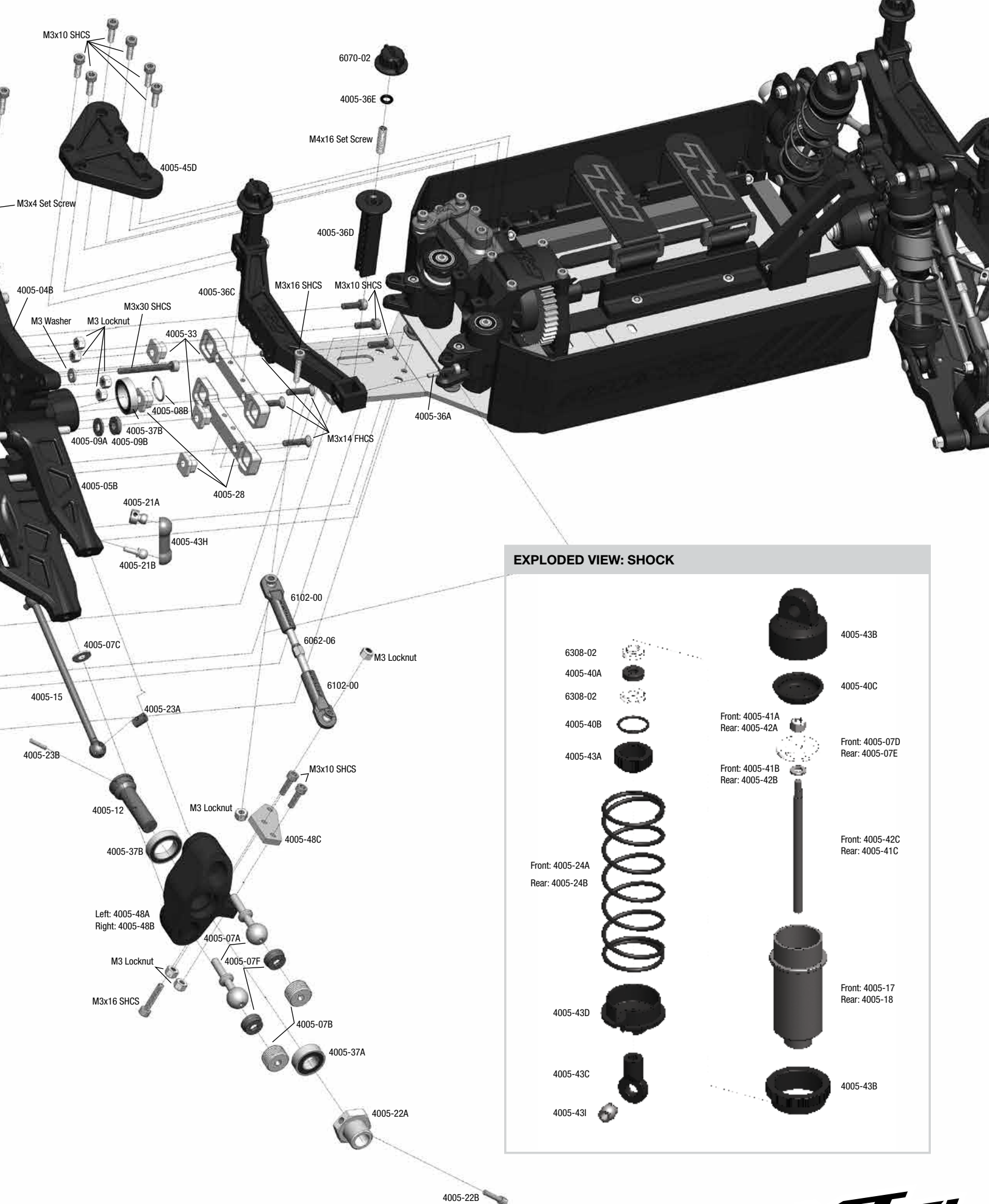

EXPLODED VIEW: SHOCK

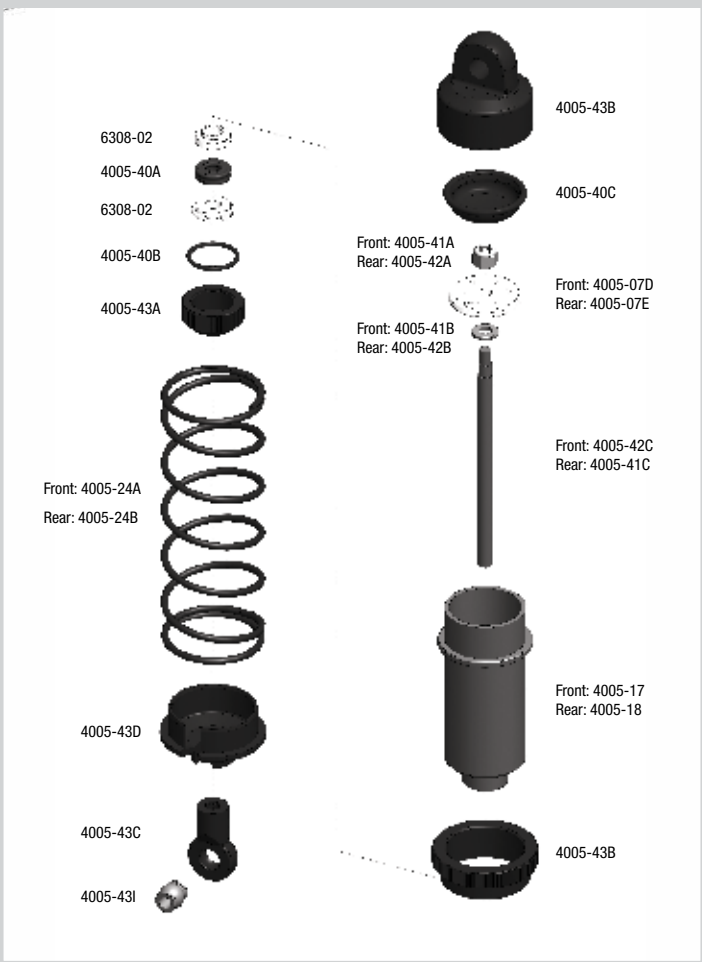

EXPLODED VIEW: CENTER

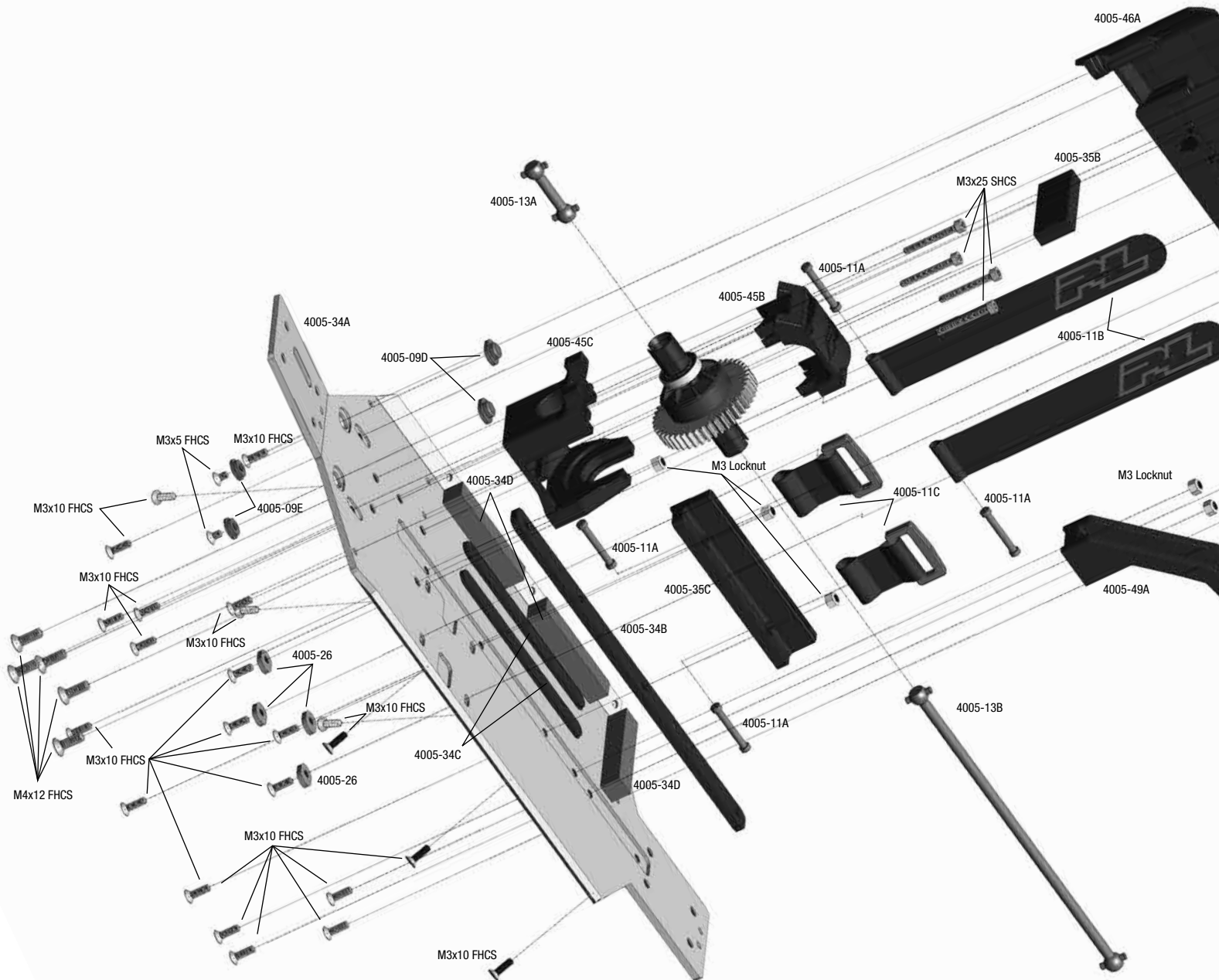

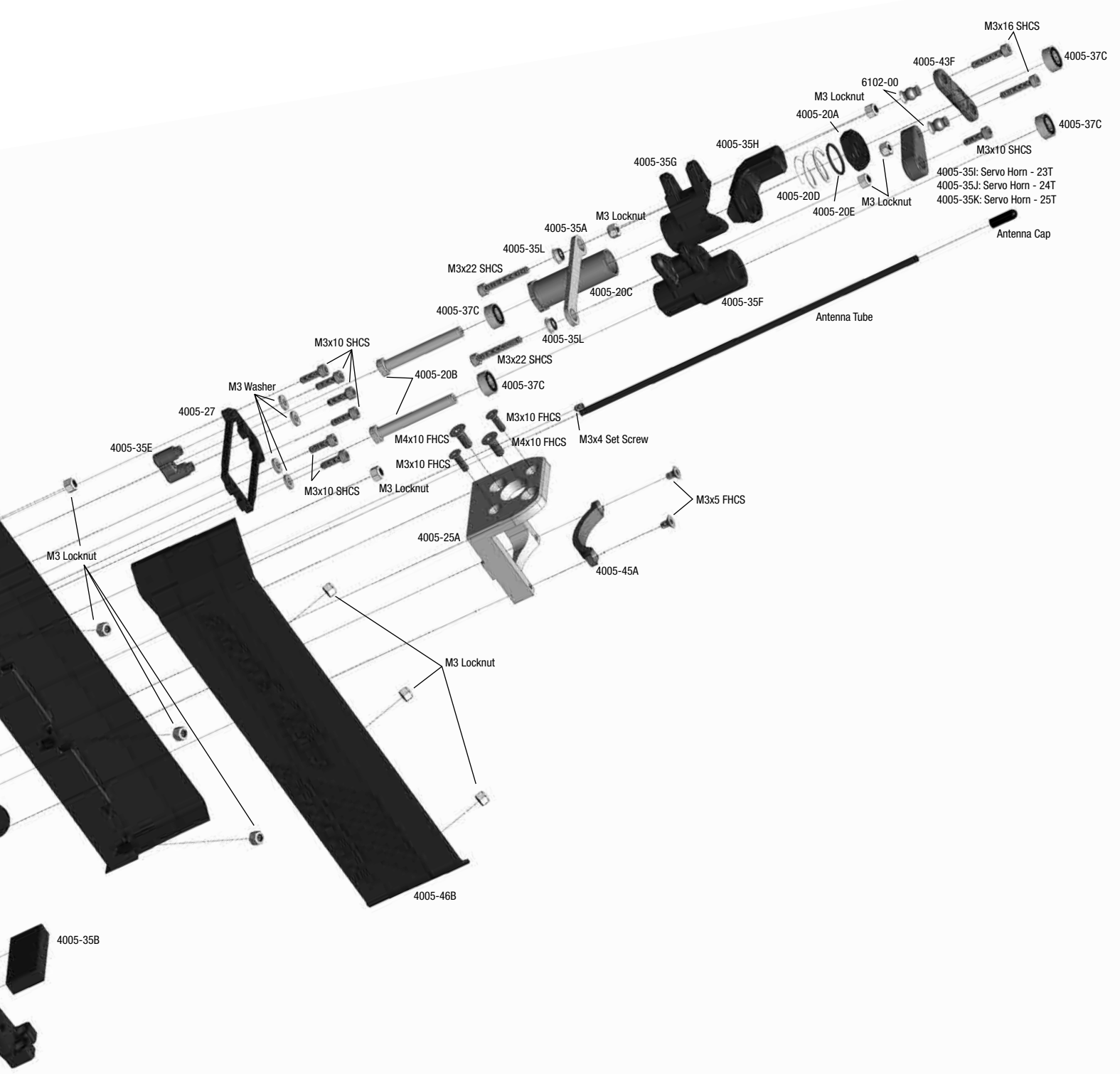

EXPLODED VIEW: REAR

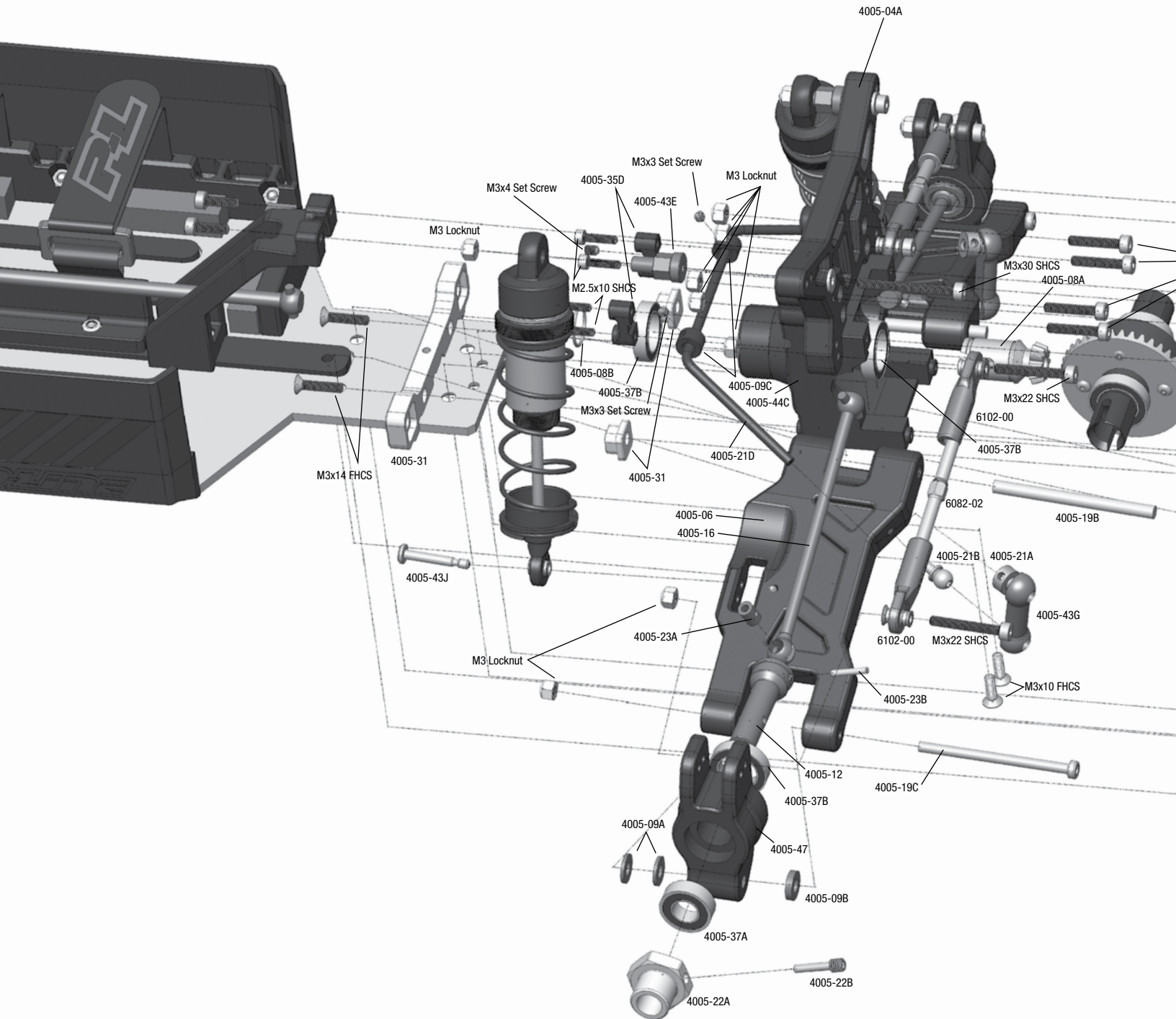

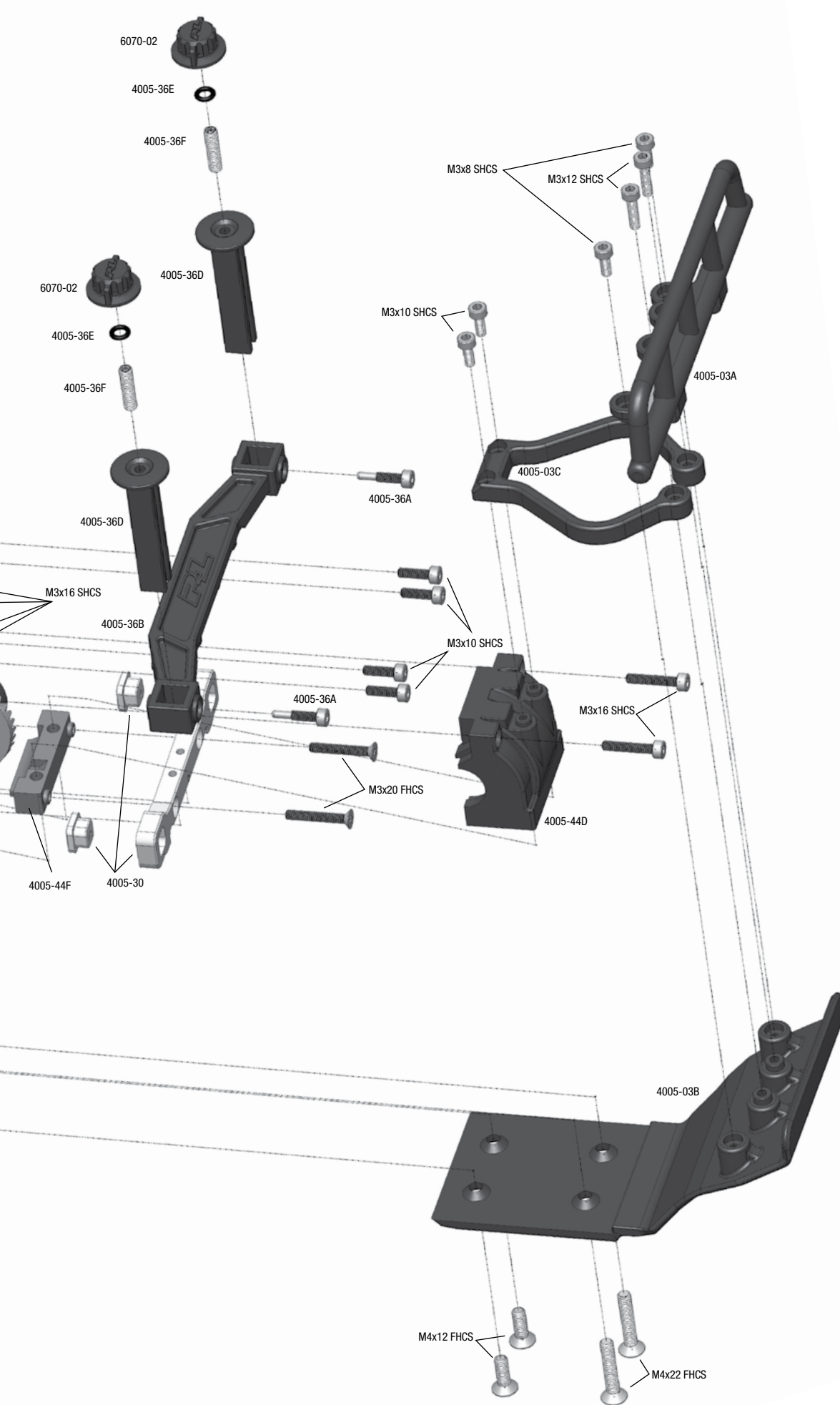

TUNING TIPS

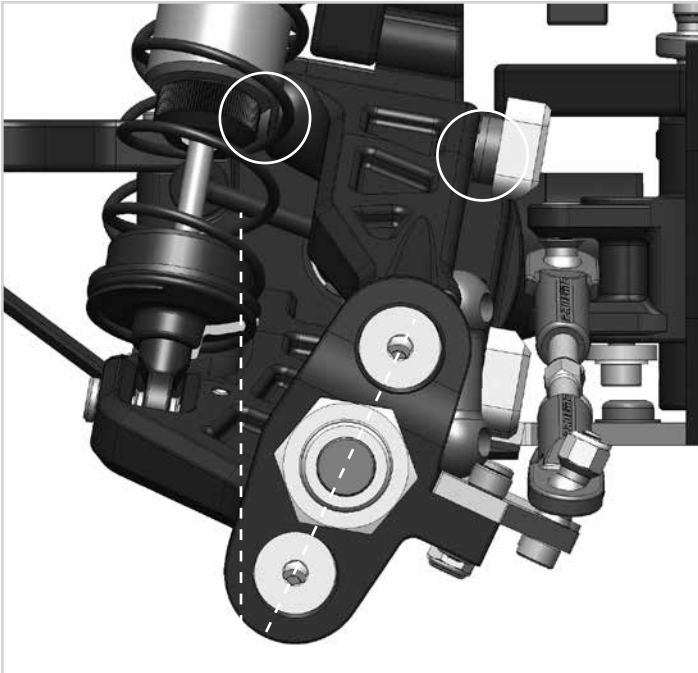

FRONT CASTER

This is the angle of the front hub from vertical when viewed from the side of the PRO-MT 4x4. It is adjusted by swapping or changing the combination of the 1mm and 2mm spacers on the front upper hinge pin. (see circled items above)

The PRO-MT 4x4 has 10 Degrees of front kick-up with adjustable front caster angle from +10° to +20°. The stock setting is +15° of caster.

Less caster angle typically provides more aggressive steering and does not handle bumps as well, while more caster angle is easier to drive and handles bumps better.

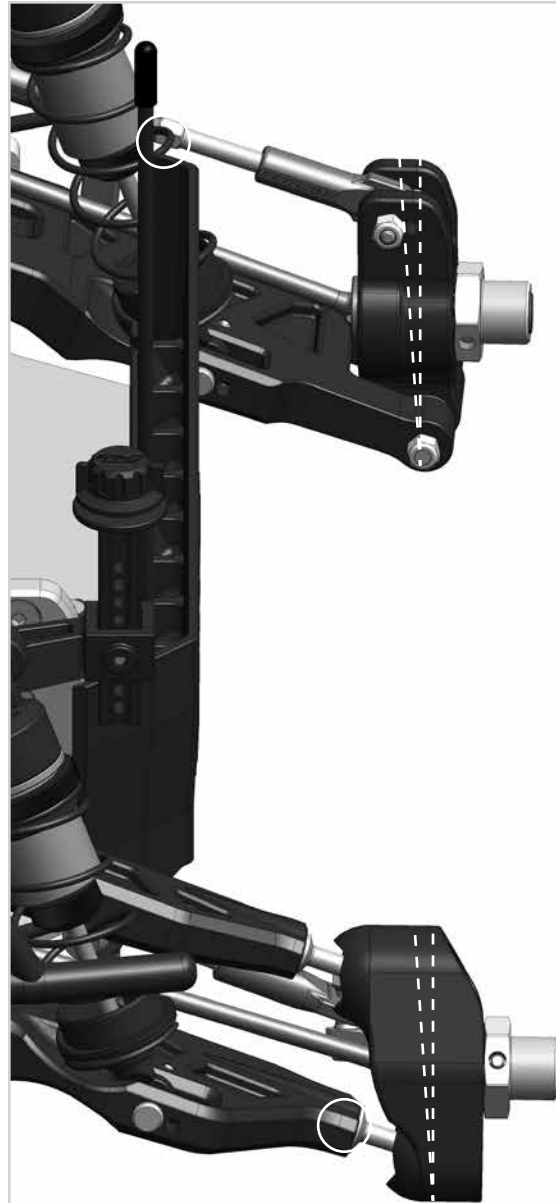

CAMBER

This is the angle the tires are leaned in towards the center of the vehicle.

The front camber angle is adjustable by using the included 0.75mm metal spacers under the lower pivot balls. Each spacer increases camber by 2°. One 0.75mm spacer is installed from the factory, so the stock front camber setting is -2°.

The rear camber link turnbuckles are adjustable just like many race vehicles. Shortening this turnbuckle will increase camber. Stock setting is -2°.

Increased front camber will increase steering. Increased camber overall generally provides more traction and stability while cornering.

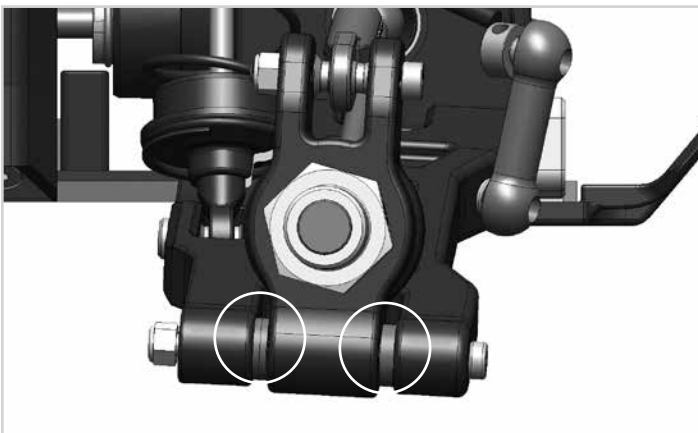

WHEELBASE

The wheelbase on the PRO-MT 4x4 is adjustable up to 4mm by moving the spacers next to the rear hub carriers. The stock setting is in the middle. A longer wheelbase is typically more stable, while a shorter wheelbase will turn sharper.

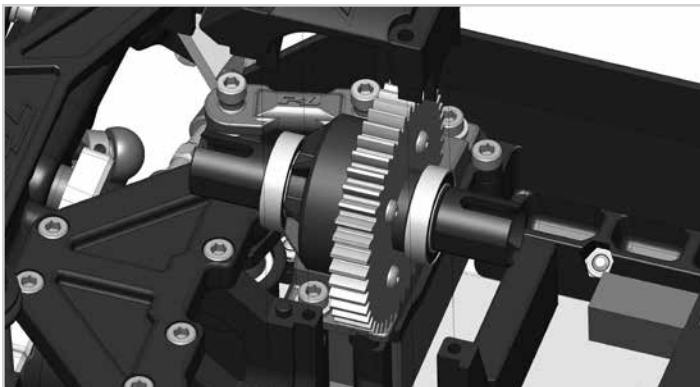

CENTER DIFFERENTIAL

Stock oil included in the center diff is 100,000 cSt.

When using 1:8 buggy motor systems with 4S Lipo power, you may find that the center diff is sending too much power to the front wheels when the truck wheelies. To provide more balanced wheel speed front to rear with extreme power systems, use heavier diff fluid in the center diff. 1 Million cSt diff fluid is generally a good place to start.

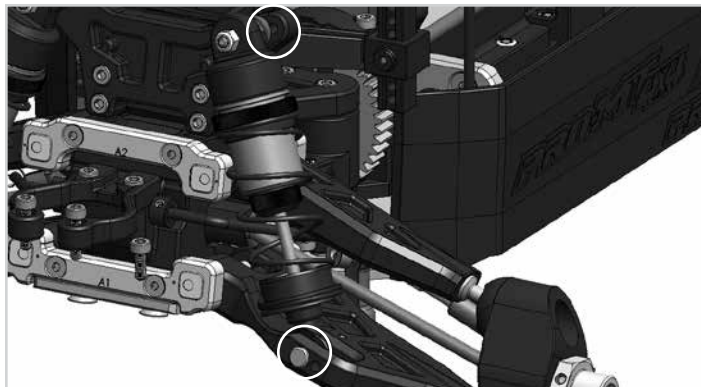

SHOCK OIL & LOCATION

Stock shock oil for the PRO-MT 4x4 is 40wt. There are two shock mounting locations on the shock towers and two on the lower arms.

The stock locations are on the inside holes, front and rear. This provides a smooth steering response and helps absorb bumps in rough terrain. The outer holes on the tower and arm provide a stiffer, more direct feel, while the outside hole on the arm also limits downtravel.

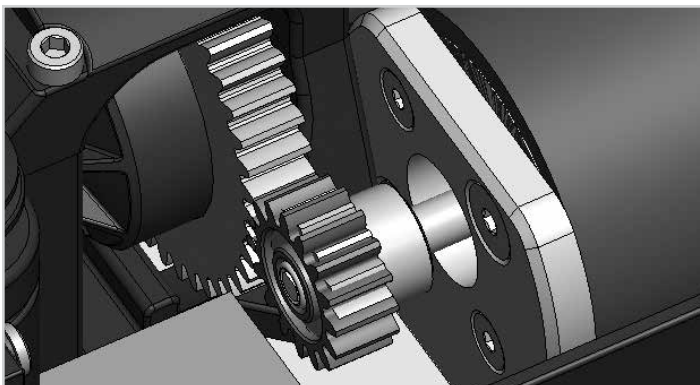

MOTOR & GEAR RATIOS

The Internal Gear Ratio of the PRO-MT 4x4 is 4:1 and the included Mod 1 Spur Gear is 44T.

A 16T Mod 1 Pinion Gear is included as a good starting point for most applications. If using a less powerful 550 motor, using a smaller pinion gear might be necessary to prevent the motor system from overheating.

When using high powered 1:8 Motor Systems and 4S Lipo power, Pro-Line testing has found motors in the 1900 kV range to be best for using the full range of Gear Ratios available (14T to 21T).

Larger pinion sizes typically provide higher top speeds but reduced bottom end power, while smaller pinion sizes are opposite. When using higher kV 1:8 motors with 4S Lipo power, start with the smallest pinion gear to prevent the motor system from overheating. If the battery is extremely hot, and/or the motor is so hot that you cannot touch it, use a smaller pinion gear.

Pinion Size	14	15	16	17	18	19	20	21
Final Gear Ratio	12.6	11.7	11.0	10.4	9.8	9.3	8.8	8.4
Rollout (Inches per motor revolution)	1.30	1.40	1.49	1.58	1.67	1.77	1.86	1.95

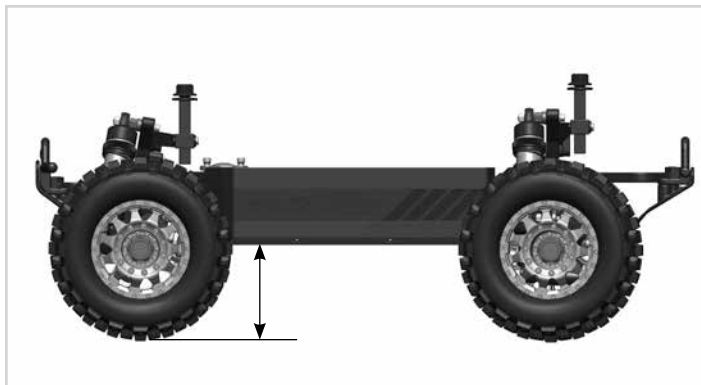

RIDE HEIGHT

This is the height of the chassis in relation to the surface. It is an adjustment that affects the way your PRO-MT 4x4 turns and goes through bumps.

To check the ride height, drop your vehicle with tires fastened from about a 5-6 inch height onto a flat surface. Once it settles into a position, check the height of each end of the vehicle in relationship to the surface. To raise the ride height, lower the shock collar on the shock evenly. To lower the ride height, raise the shock collar. Both left and right collars should be adjusted evenly.

OPTION TIRES



SAND PAW 2.8"

A must for sand and snow conditions to throw up huge roosts!

#1186-18

Premounted on F-11 17mm hex wheels



PRIME 2.8"

If you will be using your PRO-MT 4x4 on the street or for speed runs, the Prime is your best option.

#10116-18

Premounted on F-11 17mm hex wheels



TRENCHER 2.8"

Award-winning all-terrain tire works on any surface as an alternative to the stock Badlands MX28 tires.

#1170-18

Premounted on F-11 17mm hex wheels

OPTION BODIES



FORD® F-150 RAPTOR CLEAR BODY - #3471-00



Ford Motor Company Trademarks and Trade Dress used under license to Pro-Line.



CHEVY® SILVERADO™ CLEAR BODY - #3444-00



General Motors® trademarks used under license to Pro-Line.

REPLACEMENT PARTS LIST

Part #	Part Name	Qty. in group
6062-06	50x4mm Steering Turnbuckle	2
6070-02	Secure-Loc Cap Kit	4
6082-02	60x4mm Rear Turnbuckle	2
6092-06	Diff Internal Gear Replacement Kit	1
6102-00	Pivot Ball & Rod End Set	1
6308-02	Shock Shaft Guides	4
10125-18	Badlands MX28 2.8" Tires	
	Pre-mounted on F-11 17mm hex wheels	2
3435-17	Pre-Cut Sentinel Body	1
4005-01	44T Mod 1 Spur Gear	3
4005-02		
A	Front Bumper Brace	1
B	Front Bumper Skid	1
C	Front Bumper	1
4005-03		
A	Rear Bumper	1
B	Rear Bumper Skid	1
C	Rear Bumper Brace	1
4005-04		
A	Rear Shock Tower	1
B	Front Shock Tower	1
4005-05		
A	Front Arm	2
B	Front Upper Arm	2
4005-06		
A	Rear Arm	2
4005-07		
A	Pivot Ball	4
B	Pivot Ball Set Screw	4
C	Front Camber Spacer 0.75mm	4
D	Piston 1.2mm 6 Hole (Front)	4
E	Piston 1.4mm 6 Hole (Rear)	4
F	Delrin Pivot Insert	4
4005-08		
A	10T Mod 1 Bevel Gear	1
B	Center Outdrive Clip	2
C	40T Mod 1 Bevel Gear	1
4005-09		
A	1mm Spacer	8
B	2mm Spacer	6
C	Sway Bar Collar	4
D	Chassis Plug	2
E	Chassis Plug Washer	2
F	Hinge Pin Insert	12
4005-10		
A	16T Mod 1 Pinion Gear	1
B	M4 x 4 Set Screw	1
4005-11		
A	Battery Strap Bar	4
B	Battery Strap Hook & Loop	2
C	Battery Strap D-Ring	2
4005-12	Axle	2
4005-13		
A	Center Front Dog Bone	1
B	Center Rear Dog Bone	1
4005-14	Outdrive	2
4005-15	Drive Shaft Dog Bone Front	2
4005-16	Drive Shaft Dog Bone Rear	2
4005-17	Front Shock Body	2
4005-18	Rear Shock Body	2

4005-19		
A	Front Upper Hinge Pin	2
B	Lower Inner Hinge Pin	4
C	Rear Outer Hinge Pin	2
4005-20		
A	Servo Saver Adjustment Nut	1
B	Steering Post	2
C	Steering Saver Hex Tube	1
D	Servo Saver Spring	1
E	Servo Saver O-Ring	1
4005-21		
A	Sway Bar Pivot Ball	2
B	Sway Bar Ball Stud	2
C	M3 x 3 Set Screw	4
D	Rear Sway Bar - 2.7mm	1
E	Front Sway Bar - 3.0mm	1
4005-22		
A	17mm Wheel Hex	2
B	M4 x 16 Modified Set Screw	2
4005-23		
A	CVD Drive Pin Cup	4
B	CVD Drive Pin - Long	4
C	M3 x 3 Set Screw	4
4005-24		
A	Front Shock Spring	2
B	Rear Shock Spring	2
4005-25		
A	Motor Mount	1
B	M3 x 10 FHCS	6
C	M4 x 10 FHCS	2
D	M3 x 5 FHCS	2
4005-26		
A	Motor Mount Insert 14t & 21t	4
B	Motor Mount Insert 15t & 20t	4
C	Motor Mount Insert 16t & 19t	4
D	Motor Mount Insert 17t & 18t	4
4005-27	Servo Mount	1
4005-28	B1 Inner Hinge Pin Holder w/ Insert 1	
4005-29	A1 Inner Hinge Pin Holder w/ Insert 1	
4005-30	D1 Inner Hinge Pin Holder w/ Insert 1	
4005-31	C1 Inner Hinge Pin Holder w/ Insert 1	
4005-32	A2 Inner Hinge Pin Holder w/ Insert 1	
4005-33	B2 Inner Hinge Pin Holder w/ Insert 1	
4005-34		
A	PRO-MT 4x4 Chassis	1
B	Center Steel Spine	1
C	Battery Foam Strips	2
D	Battery Spacer Foam	3
4005-35		
A	Center Steering Linkage	1
B	Battery Stop	2
C	Center Battery Strap Brace	1
D	Rear Sway Bar Bracket	2
E	Servo Adapter	1
F	Servo Arm Left	1
G	Servo Arm Right	1
H	Servo Saver	1
I	Servo Horn - 23T	1
J	Servo Horn - 24T	1
K	Servo Horn - 25T	1
L	3x6x2.5 Flanged bearing	2

4005-36		
A	M3 x 14 SHCS	4
B	Rear Body Mount	1
C	Front Body Mount	1
D	Body Posts	4
E	1.5x6.5mm O-Ring	4
F	M4 x 16 Set Screw	4
4005-37		
A	8x16x5mm Bearing	4
B	12x18x4mm Bearing	14
C	5mm x 11mm x 4mm Bearing	4
4005-38		
A	Diff Cap	1
B	Diff Housing	1
C	4.7mm x 0.5mm O-Ring	2
D	5x8x1.5 O-Ring	2
E	5.2x15x0.2 Large Diff Shim	2
F	Diff Seal O-Ring	1
4005-39	17mm Wheel Nuts	4
4005-40		
A	X-Ring	4
B	10 x 1mm O-Ring	4
C	Shock Diaphragm	4
4005-41		
A	M2.5 Locknut	2
B	Piston Washer	2
C	Rear Shock Shaft	2
4005-42		
A	M2.5 Locknut	2
B	Piston Washer	2
C	Front Shock Shaft	2
4005-43		
A	Shock Bottom Cap	4
B	Shock Cap & Collar	4
C	Shock Rod End	4
D	Shock Spring Retainer	4
E	Shock Stand Off	4
F	Steering Servo Link	1
G	Sway Bar Link Rear	2
H	Sway Bar Link Front	2
I	Lower Pivot Ball	2
J	Lower Shock Pin	2
4005-44		
A	Front Diff Case	1
B	Front Diff Cover	1
C	Rear Diff Case	1
D	Rear Diff Cover	1
E	Front Lower Case Cover	1
F	Rear Lower Case Cover	1
4005-45		
A	550 / 36mm Motor Support	1
B	Center Diff Cover	1
C	Center Diff Mount	1
D	Top Plate	1
4005-46		
A	Side Pod - Right	1
B	Side Pod - Left	1
4005-47	Rear Hub Carrier	1

4005-48		
A	Front Hub - Left	1
B	Front Hub - Right	1
C	Front Hub Steering Plate	2
4005-49		
A	Rear Chassis Brace	1
B	17mm Wheel Wrench	1
4005-50	Pinion Reducer	1
M3 x 12 SHCS	Qty. in kit:	6
M3 x 8 SHCS		6
M3 Washer		8
M3 x 10 SHCS		26
M4 x 12 FHCS		9
M3 x 4 Set Screw		4
M3 x 14 FHCS		6
M4 x 22 FHCS		4
M3 x 22 SHCS		6
M2.5 x 10 SHCS		4
M3 x 30 SHCS		4
M3 x 10 Set Screw		4
M3 x 20 FHCS		6
M3 x 5 FHCS		4
M3 x 10 FHCS		32
M3 x 16 SHCS		16
M4 x 10 FHCS		2
Antenna Tube		1
Antenna Cap		1
M2.5 x 10 BHCS		12
M3 x 25 SHCS		4
M3 Locknut		45
M2.5 Locknut		4





Pro-Line Racing
201 W. Lincoln St.
Banning, CA 92220

ProLineRacing.com

1-800-899-RACE(7223) or (951) 849-9781

customerservice@prolinerracing.com



facebook.com/prolinerracing
[@prolinerracing](https://twitter.com/prolinerracing)